

COLMAN

ENGINEERED AIR DISTRIBUTION

HIGH CAPACITY LINEAR SLOT DIFFUSERS

CB SERIES



CB
SERIES

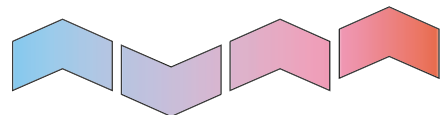

LINEAR SLOT DIFFUSER

CB SERIES

QUALITY AND EFFICIENCY WITHOUT COMPROMISE

Application

Colman's Model CB is a high capacity linear slot diffuser suited to a wide variety of applications. The combination of 25mm wide slots and the unique curved design of the air deflecting vanes enables CB to handle significantly more air per linear metre than standard slot diffusers. The advantages of using CB slot diffusers are its use for buildings which require large air change rates and on VAV applications where high turndown ratios are required.

Description

The CB linear slot diffuser is designed to give continuous air diffusion with a pleasing aesthetic appearance. Hairline butt joints held by special alignment strips ensure that continuous, unbroken runs of active and dummy sections are readily achieved. The standard diffuser comprises one to six slots (maximum 3 slots in each direction) sections complete with curved, black air pattern control blades which are fitted in 300mm lengths to provide maximum flexibility of air patterns and allows for full adjustment from the diffuser face. Constructed from high quality aluminium extrusion in maximum one piece lengths of 3000mm, the design incorporates keyways for alignment and suspension purposes. End caps are supplied as standard for single piece diffusers and for end sections of continuous runs.



Fixings

As standard the diffuser is supplied with hanger brackets for use with drop pods. Colman recommend this technique for continuous line installation. Options include an additional installation frame for use with plaster ceilings and universal brackets for use either with this extra frame or for fixing to a plenum or duct with a prepared opening. The maximum recommended lengths for this method is 3m.

Please note, separate brochure is available covering installation details of all Colman slot diffusers.

Please contact us should you require a copy.

Finish

The slot diffuser is available as standard, powder coated in RAL 9010 Matt White. Please refer to the product coding section within this brochure for a list of other standard finishes. Special finishes are available on request.

Options and Order Codes

Diffusers

1	2 FRAME	3 BLADE TYPE	4 ACCESSORIES	5 ARRANGEMENT	6 FIXING	7 FINISH
C	B Adjustable blades Surface Mounted	O None	O None	O None	O None	F RAL9010 Matt White
	F CB Diffuser with special outer frame	A Black Anodised Aluminium	A Standard 25mm end cap	A Intermediate - no end cap	H Hanger brackets for drop rods	Other standard colours available; Mill Finish O
	X Blanking plate	P Black Plastic	B Standard end plate	B Straight - 2 end cap	P Plaster mounting frame (includes universal brackets)	Anodised A
	1 Special	1 Special	C Non standard end cap	C Straight - R/H end cap	U Universal mountings brackets	Satin Anodised 9
			1 Special	D Straight L/H end cap	X Extended hanger brackets	BS00E55 Gloss White C
				E Mitred Corner - 90°	1 Special	BS00E55 Satin White H
				H Non standard mitred corner flat ceiling mounted		BS00E55 Matt White D
				1 Special		RAL9010 Gloss White E
				Note Specify mitre angle, template may be required		RAL9010 Satin White G
						RAL9006 Aluminium 3
						Matt Black 8
						Special Colours available on request 1

Note: The items shown in red above and in the order code example below are the standard options for this product. Unless shown otherwise on any quotation or order the units will be supplied in this configuration.

Example of Order Codes

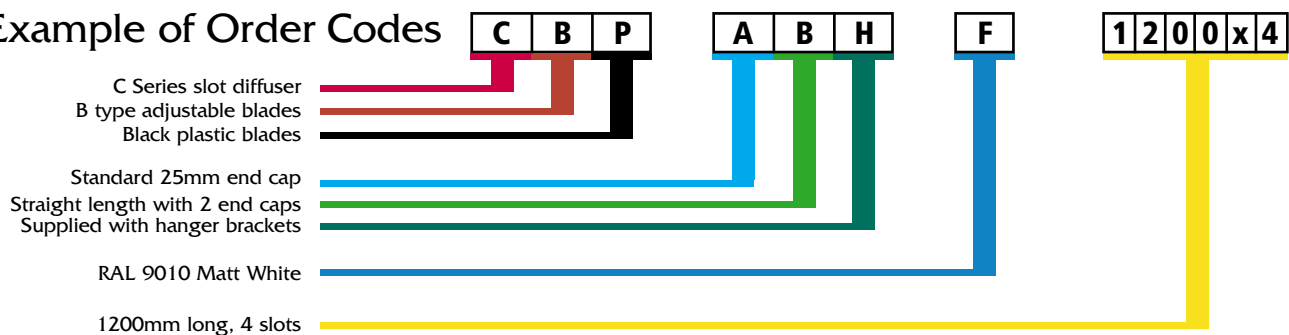

CB Plenum Boxes

1	2 LINING	3 INSTALLATION METHOD	4 ACCESSORIES	5 ARRANGEMENT	6 SPIGOT TYPE	7 SPIGOT SIZE (DIA OR SQ - all in mm)
C	L Lined (6mm Bestobell)	B Clip on plenum with hanger brackets	O None	S Supply	R Round - Side entry	A 100
	N Unlined	E Plaster mounting frame	M Mono blade cord operated damper	E Extract	S Square - Side entry	B 125
	1 Special	C Universal mounting brackets	N Mono blade cord operated damper painted matt black (internally only)	1 Special	T Round - Top entry	C 150
		1 Special	P No Accessories painted matt black (internally only)		W Round - Flush with top of unit	D 200
			1 Special		X Square - Flush with top of unit	E 250
			Note Max size mono blade Ø400 and 350sq		Y Square - Top entry	F 300
					1 Special	G 350
						H 400
						J 450
						K 500
						L 160
						M 180
						N 315
						T 175
						R 225
						P 280
						S 355
						1 Special
						All standard spigots 75mm deep

SPECIFICATION

The CB slot diffuser is manufactured from 1.5mm extruded aluminium to BS 1474/6063T6. Outer frames are formed from extruded aluminium and contain key ways to facilitate independent suspension of the unit from all surfaces. This shall be achieved by use of suspension brackets or universal fixing brackets. The slots shall be 25mm wide and contain adjustable pattern blades, to provide control of the air pattern in either direction along the length of the diffuser or to provide positive blanking of a section or slot. The blades to be curved black plastic in 300mm lengths.

Selection Information

The following pages give details on how to correctly select the CB slot diffusers, together with a worked example.

Please read the notes carefully and contact us should you have any queries.

Table 1:
Diffuser Length correction figures

Active Diffuser length (m)	Factor	NR Correction
0.3	0.52	-5
0.6	0.88	-2
0.9	0.98	0
1	1	0
1.2	1.04	1
1.5	1.09	2
1.8	1.14	3
2.1	1.17	3
2.4	1.19	4
2.7	1.2	4
3.0+	1.21	5

Throws

Throw and NR data is given for 1m active lengths use the correction figures given in table 1. If two diffusers are to throw towards each other, select an air volume that gives a maximum throw equal to half the distance between the two.

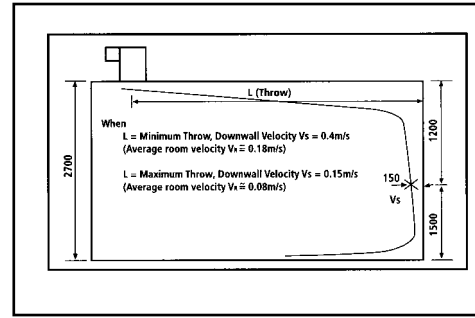

Table 2:
Spigot velocity against NR rating

Sound Rating NR	Spigot Velocity m/s
25	2.5
30	3
35	3.5
40	4.5

Pressure Drop

The pressure drop is given for the diffuser only.

Plenum Height

The plenum box height is calculated as follows:

plenum box height = 300mm x plenum length. Example: Active plenum length = 1.8m Plenum box height = 300 x 1.8 = 540mm.

Note: The plenum height must be greater than spigot diameter plus 100mm

Typical Selection

Given: Room size 6m wide x 5m long x 2.7 high
required NR level 30
Air volume = $0.54\text{m}^3/\text{s}$
The diffuser is positioned in the middle of the zone.
•• The throw is 2.5m in both directions

1) From the performance data given for a throw of 2.5m in one direction a two slot diffuser at a volume of $0.6\text{m}^3/\text{s}$ gives a throw of 1.9m - 2.9m, 5 Pa, NR < 15.

2) Calculate Active length

Due to half the air throwing in one direction the volume for half the room is $0.27\text{m}^3/\text{s}$.

•• Active length = $\frac{0.27\text{m}^3/\text{s}}{0.06\text{m}^3/\text{s}/\text{m}} = 4.5\text{m}$

Note: The actual diffuser would be a 4 - slot diffuser orientated so that 2 slots discharge in opposite directions.

Due to the active length being 4.5m this cannot be made in one continuous plenum box and 3 off plenums should be used each 1.5m long.

Due to the 1.5m length of each plenum a correction factor to the throw should be applied. Therefore from table 1, the factor is 1.09.

•• Min throw = $1.9 \times 1.09 = 2.07\text{m}$
Max throw = $2.9 \times 1.09 = 3.16\text{m}$ } satisfactory 2.5m throw
No correction is required for a 2.7m high ceiling

3) Select Spigot Size

Volume per spigot = $\frac{0.54\text{m}^3/\text{s}}{3} = 0.18\text{m}^3/\text{s}$

- For NR 30 a spigot velocity of < 3m/s is required.
- Area of 300mm diameter spigot = $\pi r^2 = \pi \times 0.15^2 = 0.0707\text{m}^2$

Spigot velocity = $\frac{0.18\text{m}^3/\text{s}}{0.0707\text{m}^2} = 2.55\text{m/s}$ •• Acceptable

4) Plenum Height

The plenum height is calculated by multiplying the plenum length x 300mm (see above).

•• $1.5 \times 300\text{mm} = 450\text{mm}$ plenum height

5) Check noise level

Each diffuser gives less than NR15 (from selection chart). Add 2dB for 1.5m long plenum (see table above). Due to there effectively being 6 lengths of 1.5m long 2 slot CB diffusers a further 8dB must be added. i.e. Addition = $10 \log N = 7.8\text{dB}$ where $N = 6$
Noise rating in room = $15 + 2 + 8$ Total NR25 which is less than the specified NR30.

6) Therefore the selection for this particular example is a 4 slot CB linear diffuser 6m long, 3 plenums are required each 1.5m long, 450mm high with 300mm diameter spigots, in the centre of each plenum.

- 1) Data is for flush mounted ceiling diffusers.
- 2) Data is based on normal temperature differentials on cooling up to 11 degrees C.
- 3) All NR ratings are based on a room absorption of 8db dampers fully open. Where no figure is given in the NR column the rating is less than NR15.
- 4) For ceiling heights greater than 2.7m, the throw is reduced by 5% for each additional 0.3m up to a maximum of 4.3m.

Volume $\text{M}^3/\text{s}/\text{m}$	Number of Slots	Ps (Pa)	Throw m		Sound Rating NR
			Min.	Max.	
0.020	1	2	1.0	1.8	<
0.030	1	5	1.6	2.5	<
0.040	1	9	2.1	3.3	<
	2	2	1.1	1.9	<
	3	1	0.9	1.6	<
0.050	1	14	2.6	4.0	15
	2	2	1.5	2.4	<
	3	2	1.6	2.1	<
0.060	1	20	3.2	4.8	21
	2	5	1.9	2.9	<
	3	2	1.6	2.5	<
0.070	1	27	3.6	5.5	26
	2	7	2.3	3.4	<
	3	3	1.9	2.9	<

Volume $\text{M}^3/\text{s}/\text{m}$	Number of Slots	Ps (Pa)	Throw m		Sound Rating NR
			Min.	Max.	
0.080	1	36	4.2	6.3	30
	2	9	2.7	3.9	<
	3	4	2.3	3.3	<
0.090	2	11	3.1	4.4	17
	3	3	2.6	3.7	<
0.100	2	14	3.5	5.0	21
	3	6	3.0	4.1	<
0.110	2	17	3.9	5.5	23
	3	8	3.3	4.6	<
0.120	2	20	4.3	6.0	26
	3	9	3.7	5.0	17
0.130	3	11	4.0	5.4	19
0.140	3	13	4.3	5.8	22
0.150	3	14	4.8	6.2	24

CB Extract Data

Volume M ³ /s/m	Number of Slots	Ps (Pa)	Sound Rating NR
0.030	1	8	16
0.040	1	14	19
0.050	1	22	22
0.060	1	31	27
0.070	1	42	31
0.080	1	55	34
	2	14	16
0.100	2	22	24

Volume M ³ /s/m	Number of Slots	Ps (Pa)	Sound Rating NR
0.120	2	31	29
	3	14	18
0.140	2	42	35
	3	19	23
0.160	3	25	27
0.180	3	31	31
0.200	3	39	35

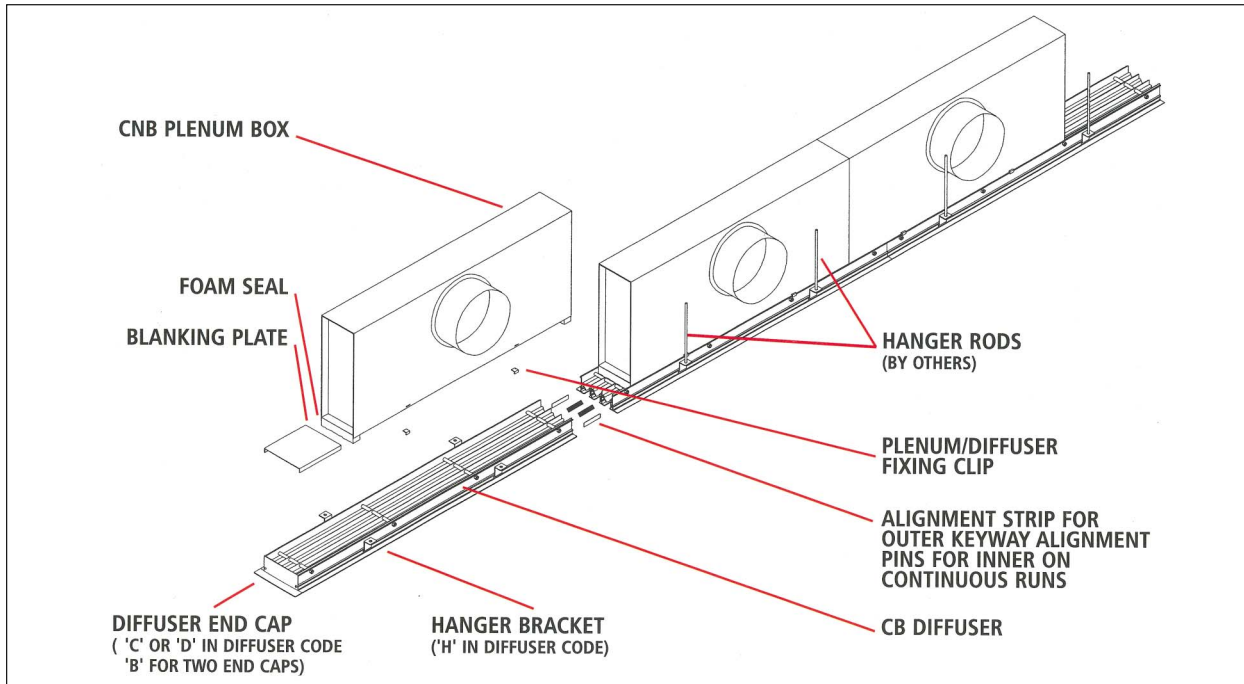

CNB/CNC Plenum Boxes

Colman manufacture a range of high quality, galvanised sheet steel plenum boxes to suit the CB range of slot diffusers. Designed to equalise the air distribution along the diffuser, these plenums are available in standard configurations or purpose made to suit different ceilings, bulkheads and air volumes. For supply air applications they will contain an equalising mesh to equalise the air along the full length of the diffuser. Plenums are normally supplied unlined but can be offered with a variety of acoustic lining materials. Supplied as standard to a maximum length of 1800mm the units are manufactured to ensure rigidity. Where lengths exceed this maximum, plenums are supplied in even lengths with a single entry spigot per plenum. As standard, plenums are supplied with a central circular spigot but oval or rectangular spigots are also available. Diffuser fixing to the plenum is either via clips (CNB) where the diffuser is fixed first and the plenum is then clipped to the back (as illustrated above) or via universal mounting brackets (CNC) where the plenum is the first fix item.

Blade setting for different air patterns

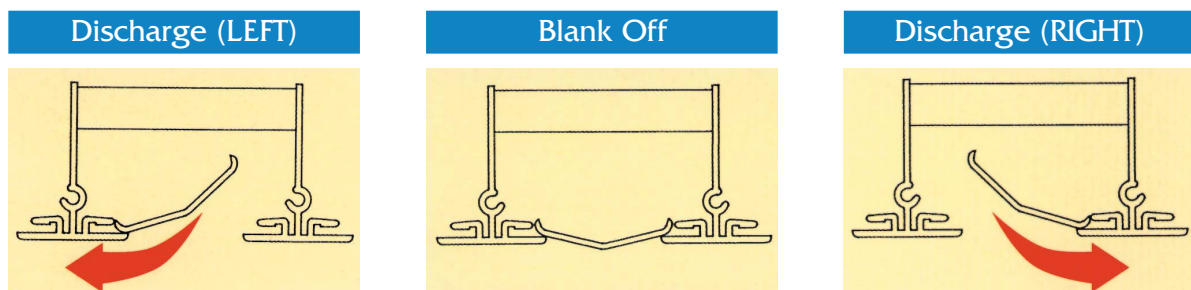

Model CBP diffuser with CNB Plenum

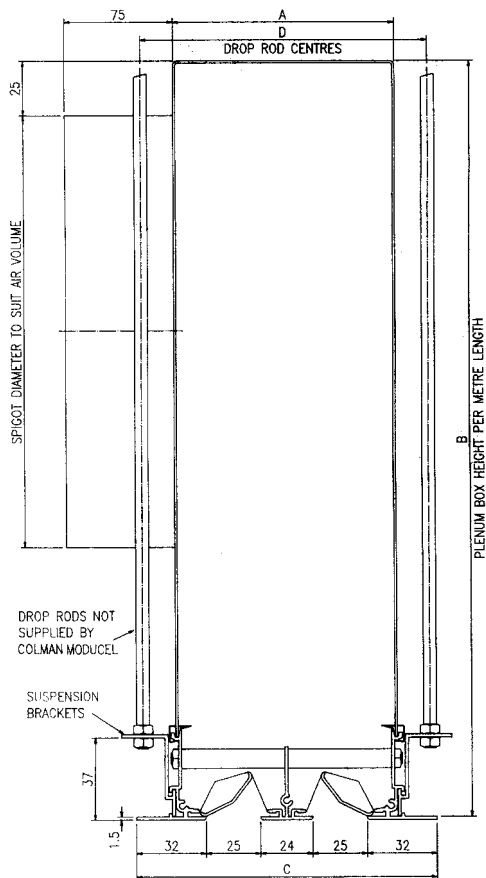

No of slots	A	B	C	D
1	54	300	89	83
2	103	300	138	132
3	152	300	187	181
4	201	300	236	230
5	250	300	285	279
6	299	300	334	328

Model CBP diffuser with CNC Plenum

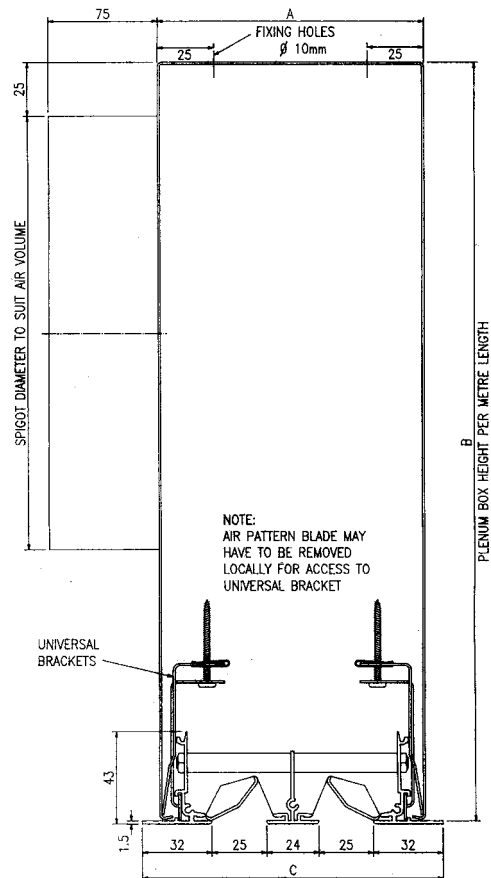

No of slots	A	B	C
1	74	300	89
2	123	300	138
3	172	300	187
4	221	300	236
5	270	300	285
6	319	300	334

Model CBP diffuser with CNE Plenum and plaster mounting frame

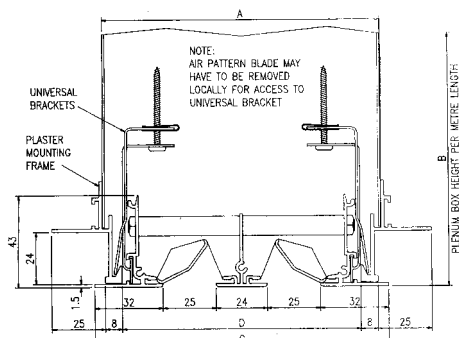

No of slots	A	B	C	D
1	81	300	89	63
2	130	300	138	112
3	179	300	187	161
4	228	300	236	210
5	277	300	285	259
6	326	300	334	308

Longitudinal Section of diffuser

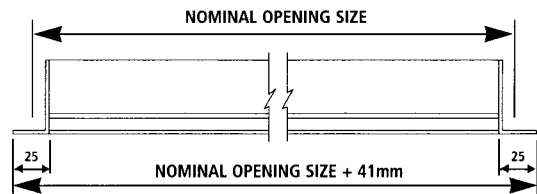

Weight Kg/m

No Slots	1	2	3	4	5	6
Diffuser	1.2	1.9	2.6	3.3	4.0	4.7
Plenum	4.7	5.1	6.5	6.9	8.1	8.5

For plaster mounting frame add 1Kg/m



Air Distribution and Air Handling
 Oldfields Business Park
 Birrell Street, Fenton
 Stoke-on-Trent ST4 3ES
 Telephone: +44 (0)1782 599995
 Facsimile: +44 (0)1782 332092
 email: colman.moducel@eaton-williams.com



Station Road, Edenbridge
 Kent TN8 6EG, England
 Telephone: +44 (0)1732 866055
 Facsimile: +44 (0)1732 869626
 www.eaton-williams.com